

Pvm. Date	Revisio Revision	Muutoksen ja korjauksen selitys Amendment and correction explanation	Muuttanut Amended

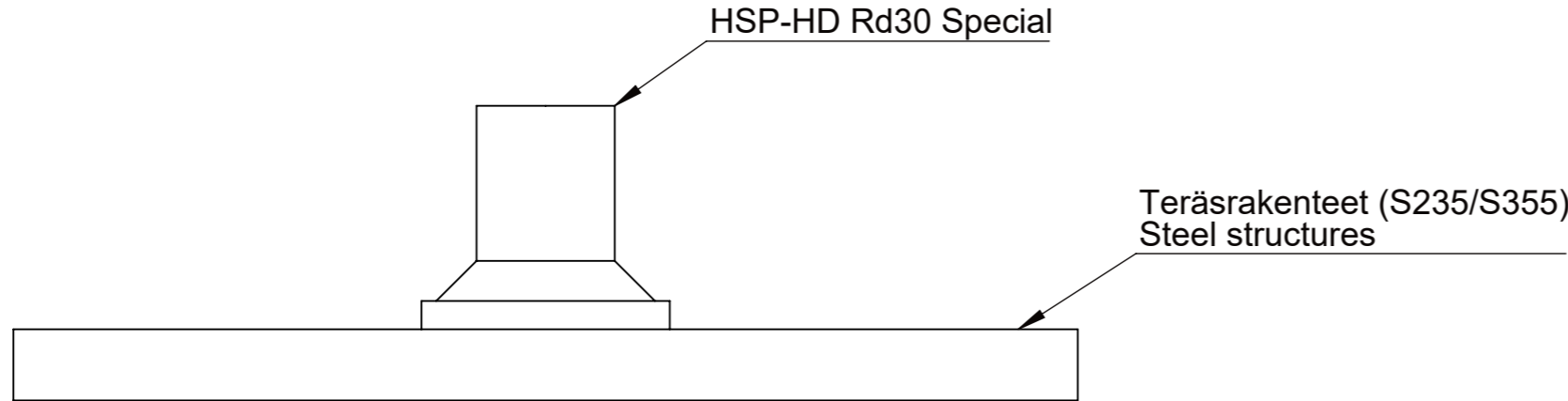

Toteusluokka EXC3 (EN 1090-2)
 EN ISO 3834-2
 Hitsauspätevyys EN 287-1
 Hyväksymiskriteeri EN ISO 5817 hitsiluokka B
 NDT EN1090-2 taulukko 24

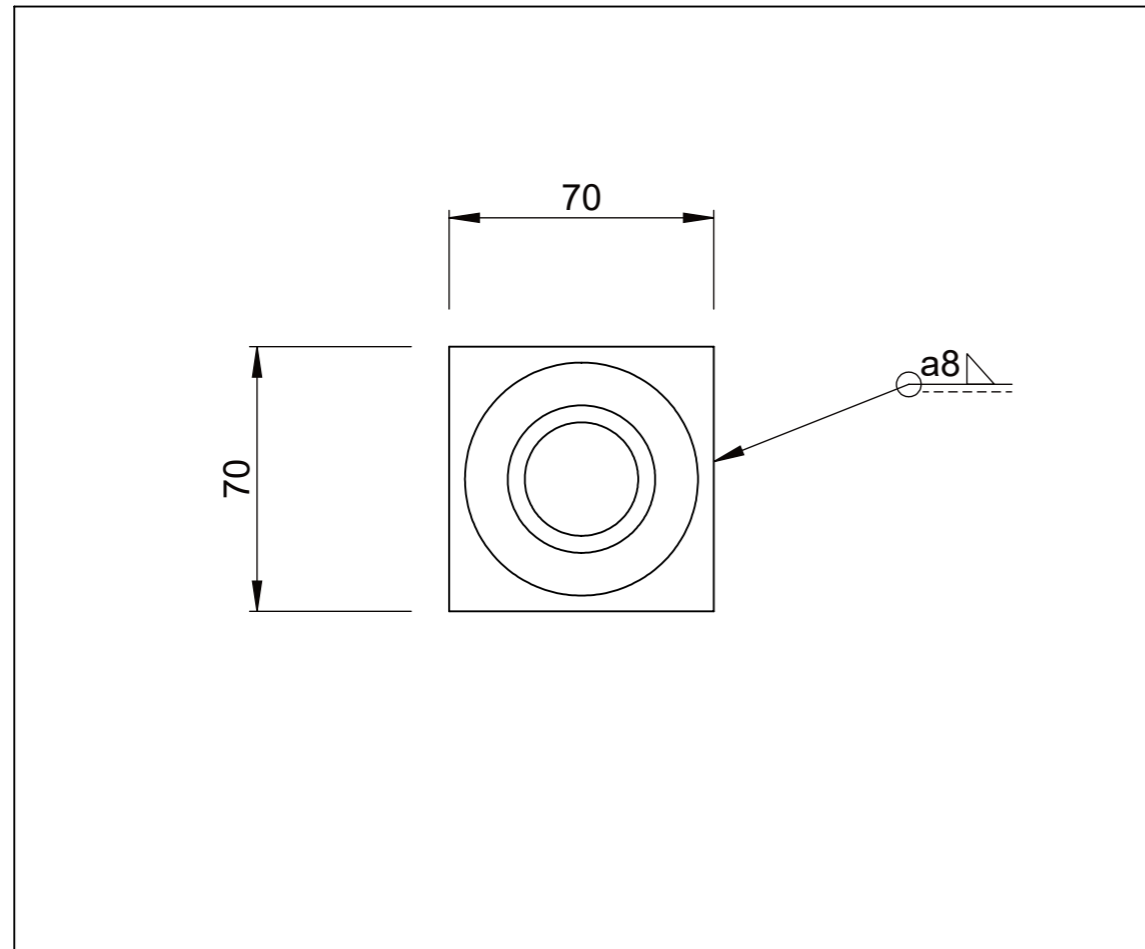

Execution class EXC3 (EN 1090-2)
 EN ISO 3834-2
 Qualification EN 287-1
 Acceptance EN ISO 5817 welding class B
 NDT EN1090-2 table 24

Hissin nostopisteen nimelliskuorma 40kN
 Lifting point nominal load 40kN

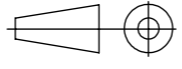
Merkitemättömät valmistustoleranssit Dimensional tolerances without tolerance indication			Hitsausluokka: Welding class: SFS-EN 25817 WC		
Lastuaminen: SFS-EN 22768-1 Keski Machining: Medium		Hitsaus: A SFS 3393 Welding:	Polttoleikkaus: II AH SFS 4072 Oxygen cutting:	Leikkaus ja taivutus: SFS 4012 Cutting and bending	
 SEM TU OY			Kokonaispaino Total weight 12.4 kg		
			Position No. Position No. 01		
Suunnitellut Designed 15.03.2023 TK			Projekti No. Project No. 10274		
Tarkastanut Checked			Liite Attachment HSP-HD Rd30 Special		
Hyväksynyt Approved			Welding instruction for lift construction attachment point		
Päiv. Date			Piirustus No. Drawing No. 10274_01_002		Muutos Revision
Nimi Name			Koko Size A3		Suhde Scale 1:2
ENTOP engineering company					